



UV Nd:YAG Laser at 355-nm Wavelength

Frequency tripling or **third harmonic generation** (THG) is a technique used to produce a wavelength that is one-third (1/3) of the fundamental wavelength of a laser. For the 1064-nm fundamental of Nd:YAG, the third harmonic wavelength is 355 nm. 355 nm lies in the ultraviolet (UV) region of the electro-magnetic spectrum, and it offers many advantages over 1064 nm and 532 nm for laser processing, among which are:

- the shorter wavelength couples (or is absorbed) more efficiently with many target materials than does the 1064-nm fundamental wavelength, and for some materials even more efficiently than the second harmonic 532-nm wavelength.
- the shorter wavelength has the potential to produce a beam focus spot which is 67 % smaller than that produced by the fundamental wavelength, and 33 % smaller than that produced by the second-harmonic wavelength.
- short wavelength lasers are valuable tools for scientific study.
- Material removal is an *ablation* process rather than a thermal process

Laser Model LDP-100MQU

Lee Laser now introduces the Model LDP-100MQU, 12-Watt UV Nd:YAG Laser at 355-nm wavelength. The LDP-100MQU is an expansion of our highly popular 50-Watt 532-nm Model LDP-100MQG. As with our SHG generators that produce 532 nm, Lee Laser's UV generator also is **intracavity** (inside the optical resonator).

It is typical for the intracavity frequency-tripled lasers to achieve their maximum average output power level in the frequency range 5-10 kHz. The LDP-100MQU achieves its rated output power of 12 Watts at 7.5 kHz. Lesser output power levels are produced at pulse rates below and above 10 kHz. A data sheet that lists performance specifications at different pulse frequencies is available.

The laser can also be configured as a LDP-100TQU for TEM₀₀ operation. The LDP-100TQU achieves its rated output power of 5-Watts at 7.5-kHz. The intracavity mode selecting aperture may be easily removed for multi-mode operation.

Benefits of Intra-Cavity THG

To produce the 355-nm UV wavelength, the fundamental 1064-nm wavelength must be **mixed** with the second-harmonic 532-nm wavelength, in the proper proportions and phase relationships,

inside the THG crystal. Wavelength conversion efficiency is proportional to the level of the

peak power density of the input beams, so a means must be found to concentrate the 1064- and 532-nm beams into the THG crystal to produce an acceptable level of UV output.

There are two ways to do this:

1. Focus coaxial 1064-nm and 532-nm beams into a THG crystal that is installed **outside** of the laser optical resonator. This is called ***extra-cavity third harmonic generation***.
2. Install the SHG/THG generator **inside** the laser optical resonator. This is called ***intra-cavity third harmonic generation***.

Extra-cavity THG Considerations

Most manufacturers of THG lasers at 355 nm use an *extra-cavity* THG design. To create the high peak power density that is needed inside the THG crystal for good wavelength conversion, the 1064- and 532-nm beams must be tightly focused into the THG crystal where they are mixed to produce the 355-nm wavelength.

However, the high power density of the focused beams onto the crystal can cause surface damage that eventually renders the crystal useless at the impact location. To extend the lifetime of the THG crystal, it becomes necessary to periodically **index** the crystal to new, undamaged sites. Eventually, the THG crystal must be replaced. The THG crystal becomes a *disposable or consumable replacement part* of the laser. THG crystal replacement may become a costly and inconvenient maintenance issue for the end user, requiring the skills of the manufacturer's service technician.

Furthermore, additional optics must be used to re-collimate the emerging UV beam.

Intra-cavity THG Considerations

Lee Laser avoids this problem by installing the THG crystal *inside* the laser optical resonator. The high level of peak power density that is needed to achieve good wavelength conversion is provided by the high circulating power of the 1064- and 532-nm beams inside the laser optical resonator. There is no need to focus the beams into the THG crystal, so the high peak-power-density condition on the surface of the THG crystal never exists. Lifetime of the THG crystal is greatly extended, and there is no requirement for re-collimating optics.

Lee Laser's greatly simplified THG generator eliminates the costly crystal index mechanism and complicated focus and re-collimating optics, so the purchase price of the laser, and the long-term operating costs to the end-user are considerably reduced.

Lee Laser's *intra-cavity THG design* provides several other useful benefits to the user:

1. high conversion efficiency from 1064 nm to 355 nm, up to 25 %, with much reduced risk of crystal damage
2. superior Q-switched pulse stability
3. permissible operation at much higher Q-switch frequencies because of better pulse stability

LBO SHG and THG Crystals

Lee Laser uses LBO (lithium triborate) as its choice of all harmonic generator crystals. LBO is as much as seven (7) times more durable than KTP (potassium titanyl phosphate) against internal, bulk damage from laser beam propagation. The crystals are housed inside temperature controlled ovens that maintain an elevated, but near-room temperature within $\pm 0.1^\circ\text{C}$. **Precise temperature control of the LBO crystal is vital to maintain a stable level of output beam power.**

SHG/THG Crystal Protection from Laser Damage

To provide maximum protection against optical damage, Lee Laser uses only optical components that have the greatest damage resistance that are commercially available. We avoid inferior optics that now are available in large quantities at very low prices, but which we know will not provide long-term reliable performance.

In a THG optical resonator, it is the SHG and THG crystals themselves that are the most sensitive to laser damage. This damage can be caused by airborne contamination that has been allowed to settle on the optical surfaces. SHG and THG crystal damage may also be caused from operation of the laser in a low-pulse-rate mode in which the high pulse energy and short pulse width combine to generate a high *peak pulse power* condition. To avoid SHG crystal and AR coating damage, Lee Laser recommends against operation at pulse rates (Q-switch frequencies) below 5 kHz, unless the laser has been specifically configured by Lee Laser to do so.

A special design feature of all Lee Laser Q-switched products also helps to protect the SHG and THG crystals from laser damage. **Pulse Quench** is a technique used by Lee Laser to suppress the high pulse energy and peak pulse power that is characteristic of the first “giant” pulse in a gated series of Q-switch pulses (ref. technical bulletin, **Pulse Quench: Lee Laser First Pulse Suppression**). For UV lasers, the giant first pulse can cause premature damage to the SHG and THG crystals. The suppression of this first pulse by Pulse Quench greatly extends the useful lifetime of the crystals.



REVISIONS				
ZONE	REV	DESCRIPTION	DATE	ECN
	A	NEW RELEASE	10-24-2008	KPK
	B	33.46 WAS 33.55	02-05-2009	JCB

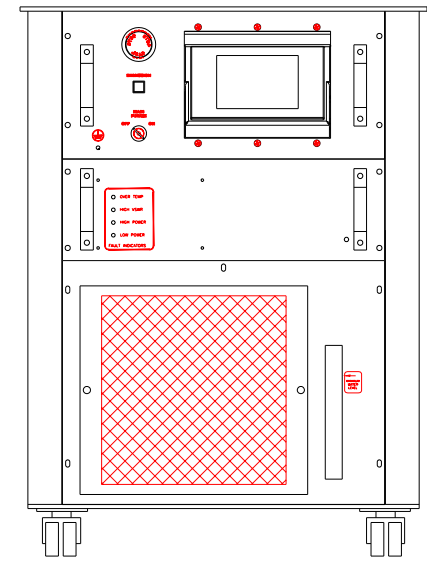
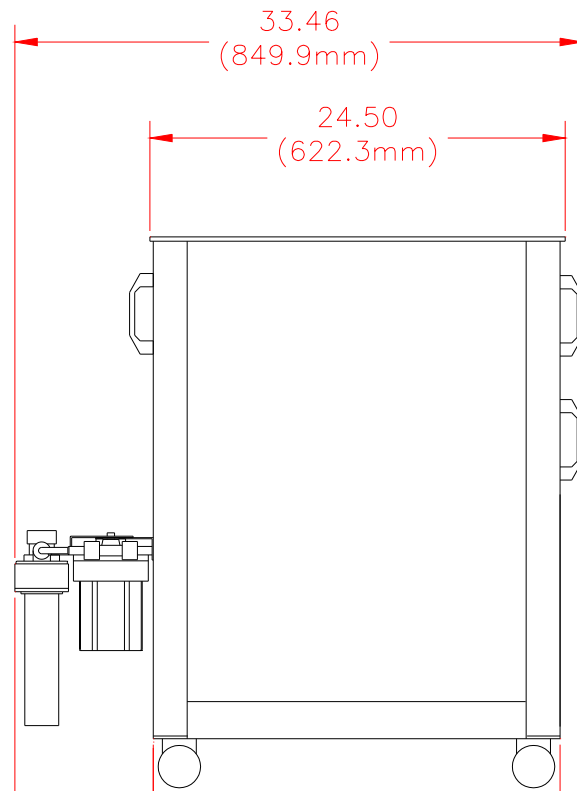
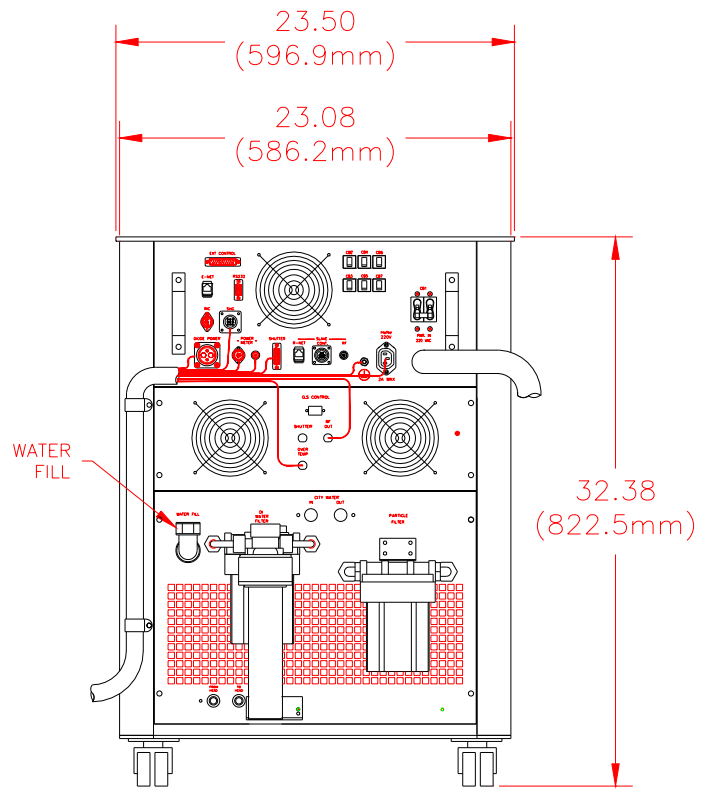

8.16 (207.3mm) 24.00 (609.6mm)

PART LIST

LEE LASER PROPRIETARY DATA:
THIS DOCUMENT CONTAINS PROPRIETARY INFORMATION OF LEE LASER, INC. IT IS TRANSMITTED TO YOU IN CONFIDENCE AND TRUST AND IS TO BE RETURNED UPON REQUEST. ITS CONTENTS MAY NOT BE DISCLOSED IN WHOLE OR IN PART TO OTHERS OR USED FOR OTHER THAN THE PURPOSE FOR WHICH IT IS TRANSMITTED WITHOUT THE PRIOR WRITTEN PERMISSION OF LEE LASER INC.

UNLESS OTHERWISE SPECIFIED: TOLERANCES: .XX = ± .XXX = ± ANGLES = ±1° DIMENSIONS ARE IN INCHES. DO NOT SCALE DRAWING.	SIGNATURES DRAWN: KPK CHECKED: ENGINEER: ISSUED:	DATE 10-24-08	LEE LASER, INC. DIODE SYSTEM OUTLINE LDP AIR COOLED REFRIG	DRAWING NO. 130389	REV B
MATERIAL		FINISH		SCALE NONE	FILE NO. 130389-B

REVISIONS			
REV	DESCRIPTION	DATE	BY / ECN
A	NEW RELEASE	02/19/2009	JCB

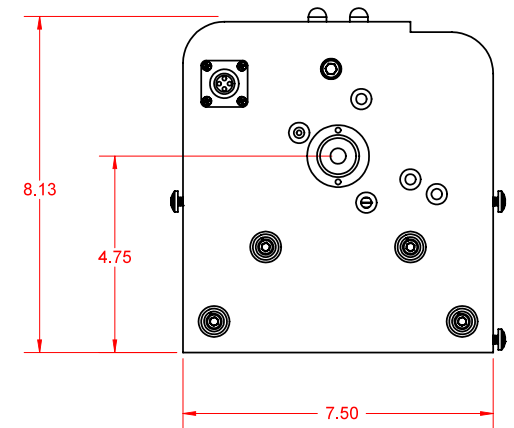
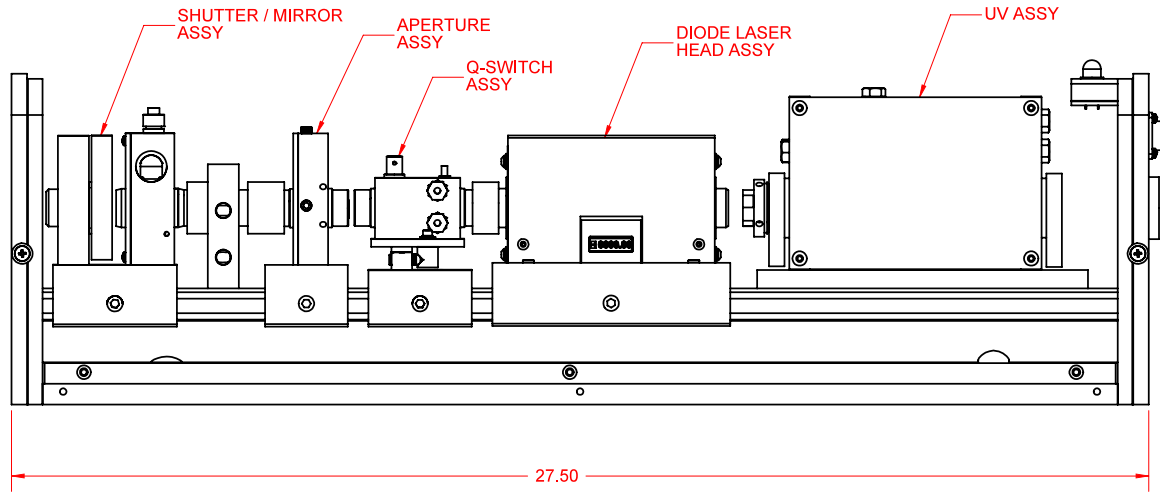

WITHOUT COVER

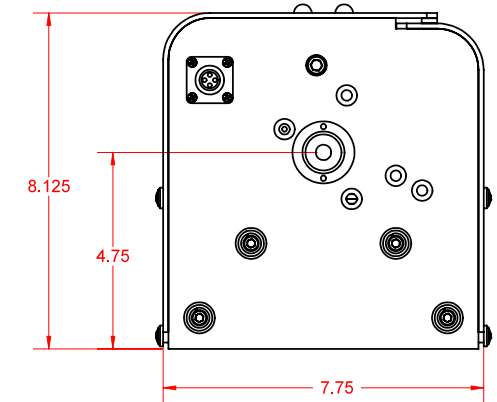
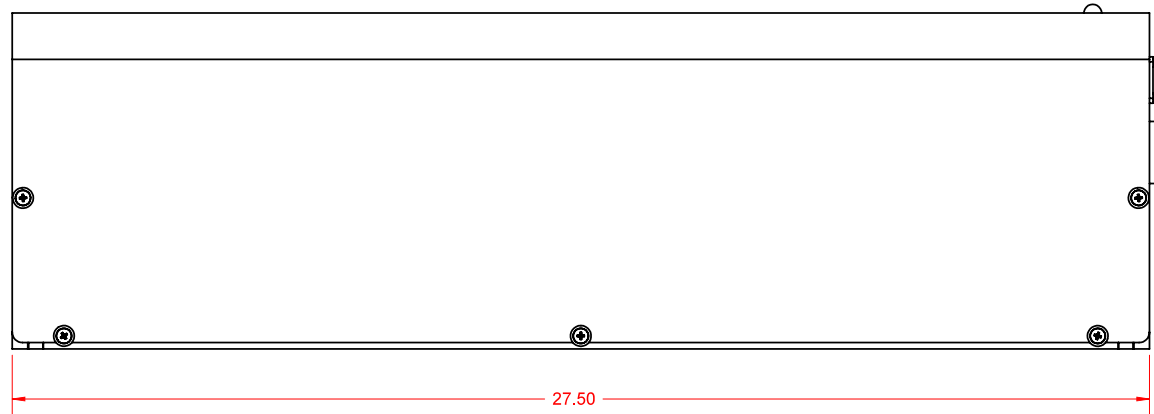

WITH COVER

<small>LEE LASER PROPRIETARY DATA: THIS DOCUMENT CONTAINS PROPRIETARY INFORMATION OF LEE LASER, INC. IT IS TRANSMITTED TO YOU IN CONFIDENCE AND TRUST AND IS TO BE RETURNED UPON REQUEST. ITS CONTENTS MAY NOT BE DISCLOSED IN WHOLE OR IN PART TO OTHERS OR USED FOR OTHER THAN THE PURPOSE FOR WHICH IT IS TRANSMITTED WITHOUT THE PREVIOUS WRITTEN PERMISSION OF LEE LASER, INC.</small>		LEE LASER, INC. RAIL ASSY, UV 27.5" LONG	
<small>UNLESS OTHERWISE SPECIFIED:</small> TOLERANCES: .XX = ± .01 .XXX = ± .005 ANGLES = ±0.5° DIMENSIONS ARE IN INCHES. DO NOT SCALE DRAWING.	<small>SIGNATURES</small> <small>DATE</small> <small>DRAWN</small> JCB 2/19/2009 <small>CHECKED</small> <small>ENGINEER</small> <small>ISSUED</small>	<small>MATERIAL</small> N/A <small>FINISH</small> N/A	<small>DRAWING NO.</small> 130398 <small>REV.</small> A <small>SCALE</small> 1:3 <small>FILE NO.</small> 130398 <small>SHEET</small> 1 of 1

REVISIONS				
ZONE	REV	DESCRIPTION	DATE	ECN
	A	NEW RELEASE	12-03-2007	JCB

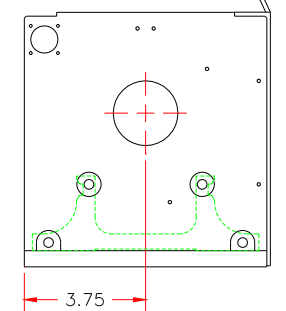
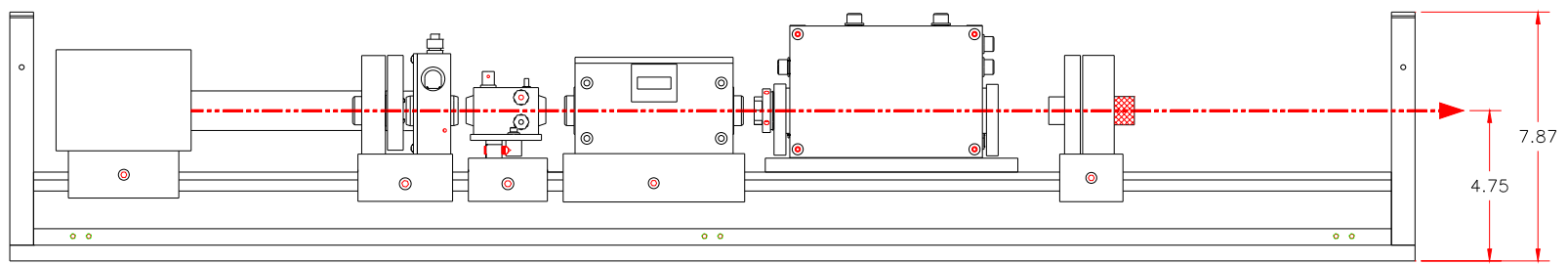
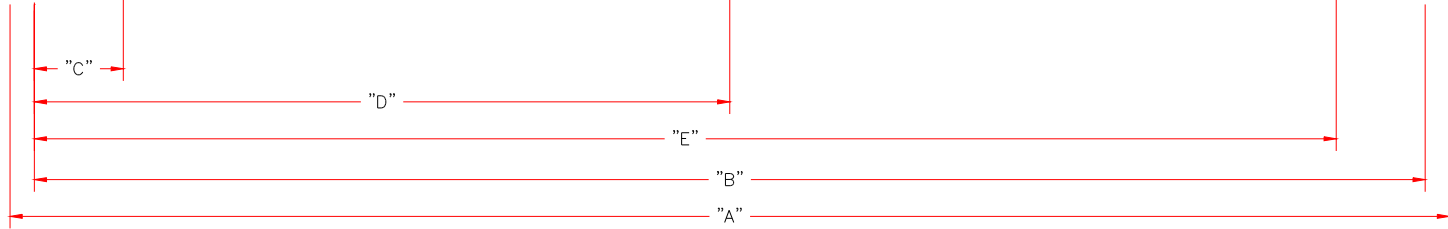
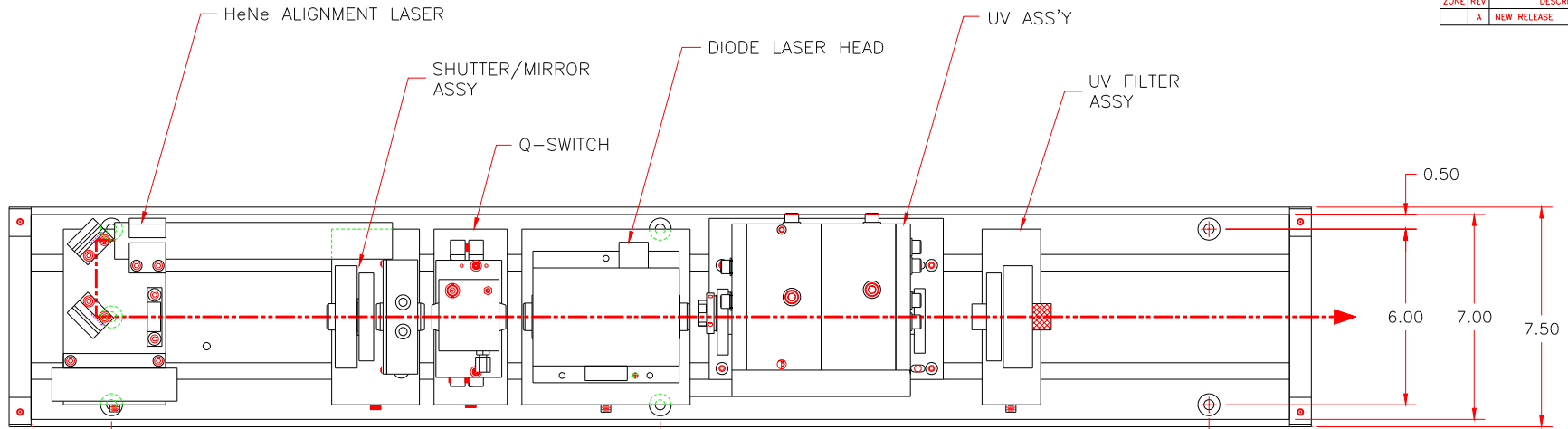

RAIL	"A"	"B"	"C"	"D"	"E"
37"	38.5"	37.0"	6.0"	18.5"	31.0"
43"	44.5"	43.0"	2.75"	18.75"	34.75
50"	51.5"	50.0"	5.0"	25.0"	45.0"

PART LIST

LEE LASER PROPRIETARY DATA:
THIS DOCUMENT CONTAINS PROPRIETARY INFORMATION OF LEE LASER, INC. IT IS TRANSMITTED TO YOU IN CONFIDENCE AND TRUST AND IS TO BE RETURNED UPON REQUEST. ITS CONTENTS MAY NOT BE DISCLOSED IN WHOLE OR IN PART TO OTHERS OR USED FOR OTHER THAN THE PURPOSE FOR WHICH IT IS TRANSMITTED WITHOUT THE PRIOR WRITTEN PERMISSION OF LEE LASER, INC.

UNLESS OTHERWISE SPECIFIED: TOLERANCES: .XX = ± .XXX = ± ANGLES = ±1' DIMENSIONS ARE IN INCHES. DO NOT SCALE DRAWING.	SIGNATURES DRAWN: JCB CHECKED: ENGINEER: ISSUED:	DATE 12-03-07	LEE LASER, INC. LDP LASER WITH THG	REV A
MATERIAL		FINISH		DRAWING NO. 130372